

Contour-accurate resharpening highest cutting performance



Control panel



Belt filter coolant unit



Suction unit

■ Optimum overheating protection

The belt filter coolant unit protects the cutting tools from overheating. A coolant monitoring device turns off the machine if the cutting tools are not being cooled enough. The coolant unit has a capacity of 140 l. A woven filter completely removes the abrasive dust from the coolant circuit. The removed material is collected on the woven filter and can be easily disposed of in an environmentally friendly way.

■ Health and safety protection

The B 600 is completely sealed. If the door is open, it is not possible to turn on a drive unintentionally.

The integrated suction unit removes floating particles from the workroom. This enables visibility during the grinding process and protects operating personnel from inhaling particles.

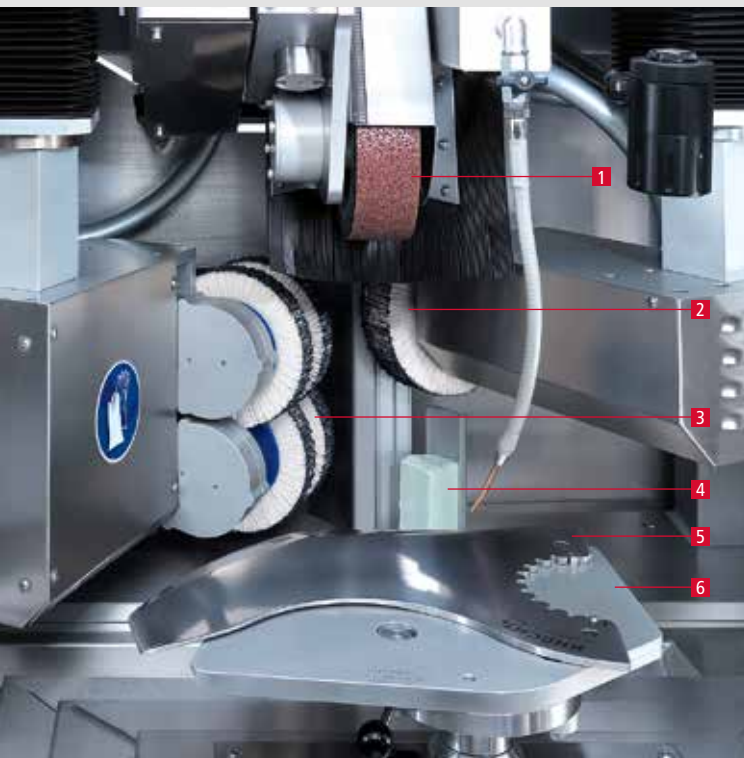

1 Wet grinding belt

2 Polishing unit

3 Deburring unit

4 Polishing paste

5 Cutter knife 500 ltr.

6 Knife holding fixture SP 114

B 600

Automatic grinding and polishing machine

Technical specifications

■ Depth (including magazine extension module)	2184 mm
■ Width (including belt filter coolant unit)	2754 mm
■ Height	1790 mm
■ Weight	700 kg
■ Electrical supply	11 kW 3x 400 V 50 Hz
■ Compressed air supply	6,5 bar
■ Air consumption	50 l per minute
■ Largest cutting tool	600 x 400 mm
■ Effective grinding performance	80 knives/day (8 hours) (cutter knife 500 – 750 ltr.)

The machine meets the **EC safety** and **health requirements** and is provided with the **CE symbol**.

We reserve the right to make technical modifications.

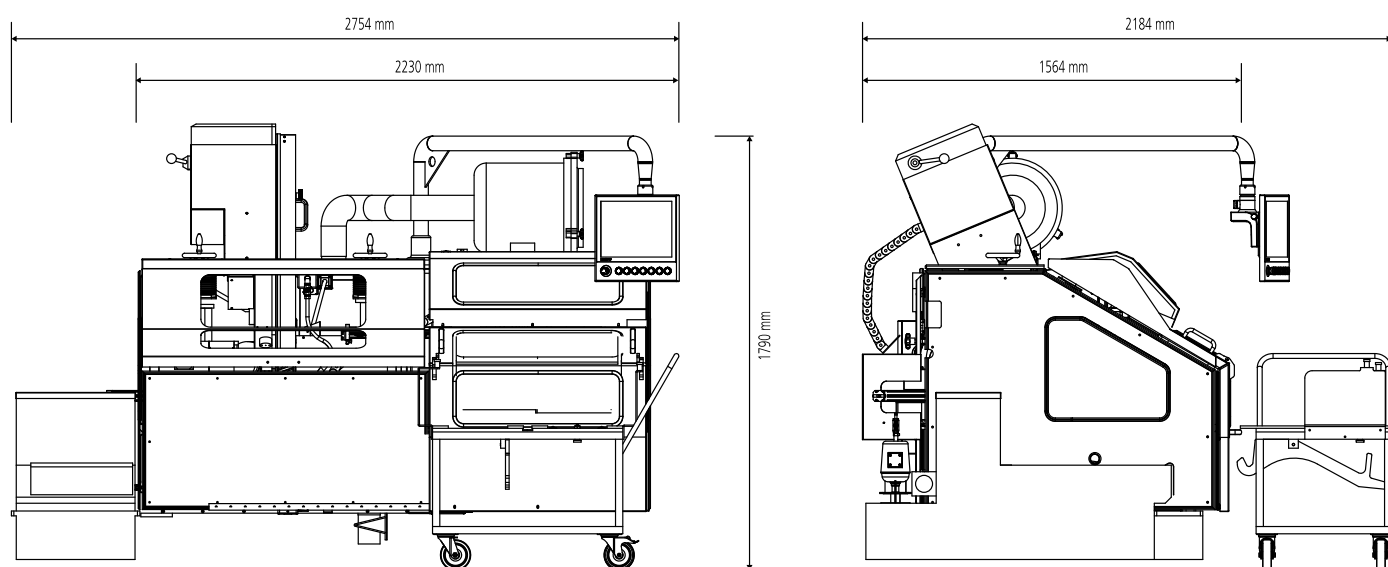

Knecht Maschinenbau GmbH

Witschwender Strasse 26 ■ 88368 Bergatreute ■ Germany
Phone +49 - 7527-928-0 ■ Fax +49 - 7527-928-32
zentrale@knecht.eu ■ www.knecht.eu

B 600

Automatic grinding and polishing machine



KNECHT

B 600

Automatic grinding and polishing machine



The sharpness, cutting edge angle, shape and profile of a cutter knife have a large impact on the quality of the sausage products produced.

High cutting speeds (up to 180 m per second, which corresponds to 650 km per hour) and side pressure put a very high mechanical strain on the cutter knife. Thus, the polished edge of a cutter knife has a direct impact on its break resistance.

Higher safety – higher quality



Knife magazine extension module (optional)



3-axis controlled cross- and rotary table

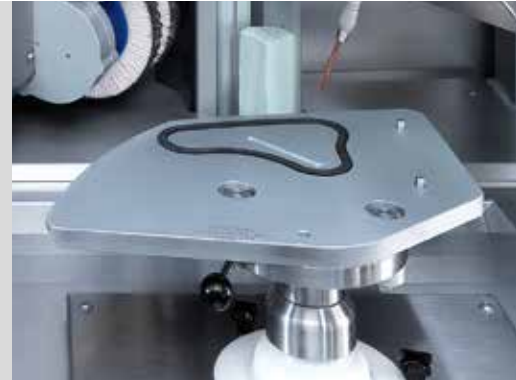

Knife holding fixture SP 114

Therefore, it is a must for a sharpening machine to fulfill the following requirements:

- **Angle-exact and precise sharpening,**
- **preservation of the stipulated blade profile,**
- **preservation of the blade's original shape.**

And this must be reproducible over the entire service life of the cutter knives.

■ Fully automated grinding and polishing process

The operator fills the magazine with up to 16 knives. After pressing the start button, the knife changer removes the first knife from the magazine and automatically transports it to the grinding position. After the grinding process the knife is brought back and the next knife is picked up.

An approach check detects the wear of the knife and starts the grinding program. The grinding unit approaches the knife and processes the cutting edge in accordance with the selected grinding program.

After grinding, the machine first polishes the knife surface. Then 4 flap brushes are used to quickly and gently deburr the cutting tool. The knife stack is shifted during the grinding process, so that the next knife is ready.



Knife magazine with knife changer

Automatic grinding and polishing machine

B 600

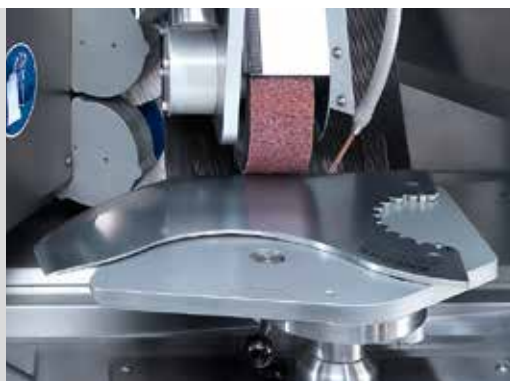

Grinding



Polishing



Deburring

■ Knife types

Flat machine knives with sickle-shaped and straight cutting edges can be sharpened. The maximum size is 600 x 400 mm with a weight up to 5 kg.

■ Knife magazine

The knife magazine can hold up to 8 knives. It can optionally be expanded to 16 knives.

■ Knife holding fixture SP 114

The knives are clamped on the knife holding fixture by a vacuum. Multiple knife shapes and sizes are assembled in groups and can be ground with only one knife holding fixture. In less than 1 minute the machine is changed to a different knife shape.

■ Abrasives

Water resistant wet-grinding belts are used to sharpen knives on this machine. One grinding belt will sharpen up to 80 cutter knives (500 - 750 l). The machine automatically adjusts to the grinding performance of the grinding belt. The amount of material ground away remains constant during each grinding process. The operator uses the touch screen to control the grinding pressure.

The polishing brushes are automatically provided with polishing paste in individually programmable cycles.

■ Control system

The machine possesses 4 computer-controlled axis. Knecht creates individual grinding programs for the knives to be ground. Knife types and grinding programs are loaded online via the Internet and stored in the data memory of the machine. The user easily calls them up. This way the grinding machine can be changed from one knife type to another in a matter of seconds.

The number of grinding programs is unlimited. Updates and new programs are loaded onto the B 600 online.

This makes it very easy to operate the grinding machine. The operator determines the most important functions, such as the number of grinding and polishing cycles and the camber of the knives, directly on the machine via the touch screen. This way the knife receives a cutting edge profile tailored exactly to the product. And this happens at every resharpening.

KNECHT